

SIMPLE AND PASSIVE MERGING-ON-DEMAND METHOD FOR REACTION ENGINEERING IN DROPLET MICROFLUIDICS

Medina Hamidović¹, Uli Marta², Helen Bridle², Gerold Fink¹, Robert Wille¹,
Andreas Springer¹ and Werner Haselmayr¹
¹Johannes Kepler University, Linz, Austria and
²Heriot-Watt University, UK

ABSTRACT

This paper presents an automated method for achieving droplet merging-on-demand (MoD). The method enables for individually preprogrammed volumes of fluids to be issued and merged at precisely predetermined times. The proposed method is passive (i.e., does not require any active on-chip components) and supports a generation frequency of 10Hz for μL and mL droplets. Allowing for droplets to be generated and merged on demand, this method can be employed in reaction engineering for designing Lab-on-Chip devices where chemical interactions between two samples need to be investigated in a highly controllable manner.

KEYWORDS: Droplet microfluidics, Droplet merging, Lab-on-Chip, Reaction engineering

INTRODUCTION

Reaction engineering is an important application of droplet microfluidics where a fine control over chemical interactions of the reagents can be achieved by controlling the merging of the droplets containing those reagents. Droplet merging can be used to trigger and monitor chemical interactions and study synthesis conditions, kinetics or formation of particles. For many applications, the order of the addition of reagents is critical for the reaction. This can be achieved by containing each reagent in a separate droplet and merging the droplets at an appropriate time to trigger the reaction. Since droplet merging can affect the selectivity of a reaction, it is required that it is carried out in a highly controllable fashion. To enable such a level of control, this work introduces a merging-on-demand method.

The method is based on a previously introduced droplet-on-demand (DoD) [1] technique where individually preprogrammed volumes of fluids are issued at precisely predetermined times (see Figure 1). By applying a series of positive pressure pulses of different durations to the dispersed phase, p_d , and maintaining the continuous phase, p_c , at a constant input pressure, DoD enables for droplets of various sizes to be generated. The proposed DoD method allows for multiple generators to be independently cascaded on a single continuous channel in order to generate multiple droplets on demand - a unique feature of the proposed DoD method in comparison to other methods [2]. It is possible to synchronize the cascaded droplet generators in time and achieve controllable and stable coalescence of droplets, which ultimately leads to merging and reacting of reagents.

MERGING-ON-DEMAND

We verify the novel MoD principle by cascading two DoD generators on a shared continuous channel with the distance d between them (Figure 2a). The precise time of droplets generated by DoD₁ to reach DoD₂ can be calculated as $\delta t = d/v$ (s), where v is the velocity of the droplet inside the continuous channel. In order to achieve MoD, DoD₂ generator uses this travelling time as an information on the precise timing of its activation. This means that, if DoD₁ generator was activated at the moment $t = t_0$, the DoD₂ generator will be activated at $t = t_0 + \delta t$. Complete system is automated and once started, does not require any manual control.

EXPERIMENTAL

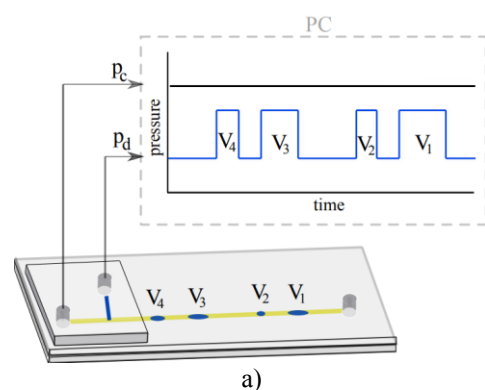

Figure 1: The principle of the DoD method for generating droplets of various sizes using positive pressure pulses.

Microfluidic devices were constructed from PMMA (Polymethyl methacrylate) sheets. A pressure controller (Elveflow, OB1MK3) was used to induce input pressures. For the evaluation of the MoD system, we used an optical microscope and to automate the system, programmed sequence of the pressure pulses was applied through the Elveflow Smart Interface Microfluidic Software. We used a silicon oil as a continuous phase, and as dispersed phase a dyed water is used to aid with the visualization of the process. Complete fabrication process can be seen at: <https://www.youtube.com/watch?v=YHap3V2njbq&t=1s>.

RESULTS AND DISCUSSION

In this work, we have proposed, and experimentally verified, a novel method that enables absolute customization of the droplet merging process. Using the method, droplets of various sizes were generated and merged in a controllable manner as show in in Fig. 2b. Video material for MoD of droplets of different sizes can be seen at: <https://www.youtube.com/watch?v=9Np5N8i-3-4&feature=youtu.be>.

We have investigated the reproducibility of the DoD method as an important metric for the droplet-based mechanisms. We define reproducibility as a possibility to achieve consistent droplet parameters (size/volume) when the same pulse is applied to the dispersed (p_d) phase. Pressure pulse with the duration of $\Delta t=0.2s$, was applied to the input of the dispersed phase. A set of thousand droplets was generated and the mean value of the droplet area, as well as the standard deviation, was measured. The results were processed using image processing tools and shown in Figure 3 in a form of a histogram. The standard deviation of only 5% of the mean value ($\mu=2.6 \times 10^5 \mu m^2$) indicates that the proposed method provides high reproducibility.

CONCLUSION

We have demonstrated that merging of droplets can be carried out in a controllable and programmable manner. Using the propose MoD method, it is possible to realize automated Lab-on-Chip devices where chemical interactions between two samples needs to be investigated (for example, investigating bacteria susceptibility for various drugs).

REFERENCES

- [1] Hamidović, M. Haselmayr, W. Grimmer, A. Wille, R. and Springer, A.: " Passive droplet control in microfluidic networks: A survey and new perspectives on their practical realization," Nano Communication Networks, 2018.
- [2] Churski, K. Korczyk, P. and Garstecki, P.:" High-throughput automated droplet microfluidic system for screening of reaction conditions, " *Lab on Chip*, 2010.

CONTACT

* M.Hamidović; phone: +43 732 2468 6383; medina.hamidovic@jku.at

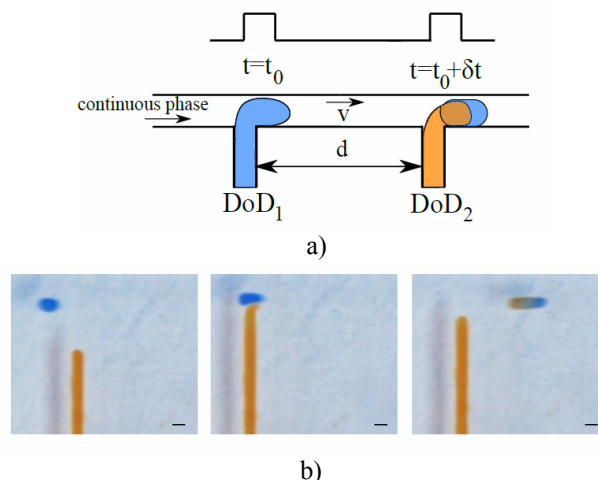

Figure 2: a) The concept of MoD: Two DoD generators are synchronized in time in order to create mixtures on demand, b) Practical realization of MoD.

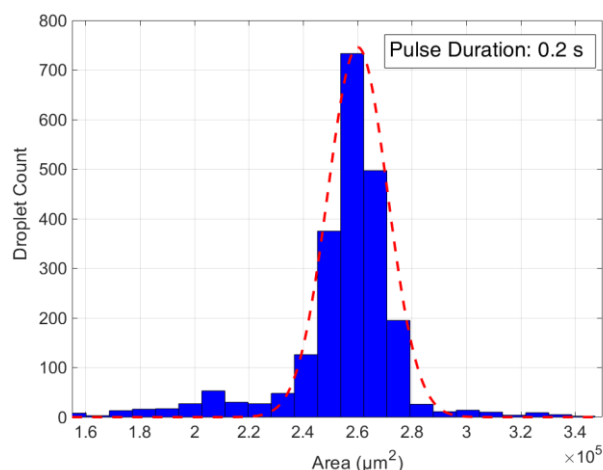

Figure 3: Reproducibility of the MoD method: High reproducibility due to less than 5% standard deviation.